

Hybrid IR Dome Camera

y

2M, WDR, STARVIS, 24IR

DTS-2024PVMHD

Picture



Feature

- 1/2.8" Sony PS **STARVIS** CMOS
- 2Megapixel TVI/AHD Hybrid format
- Day/Night with ICR
- Min 0.0003Lux with Sens-Up (32x), LED On:0Lux
- True WDR(30fps), 3DNR, Defog, OSD
- Motion Detection (4), Privacy Masking (16)
- Multi Languages (English/Chinese/Korea/Japanese)
- Built-In High Effective IR 24EA (Visible Distance: 15M)
- 2.8~12mm DC Iris Mega Lens
- 3Axis, Indoor Type
- Option: Dual Voltage

Dimensions

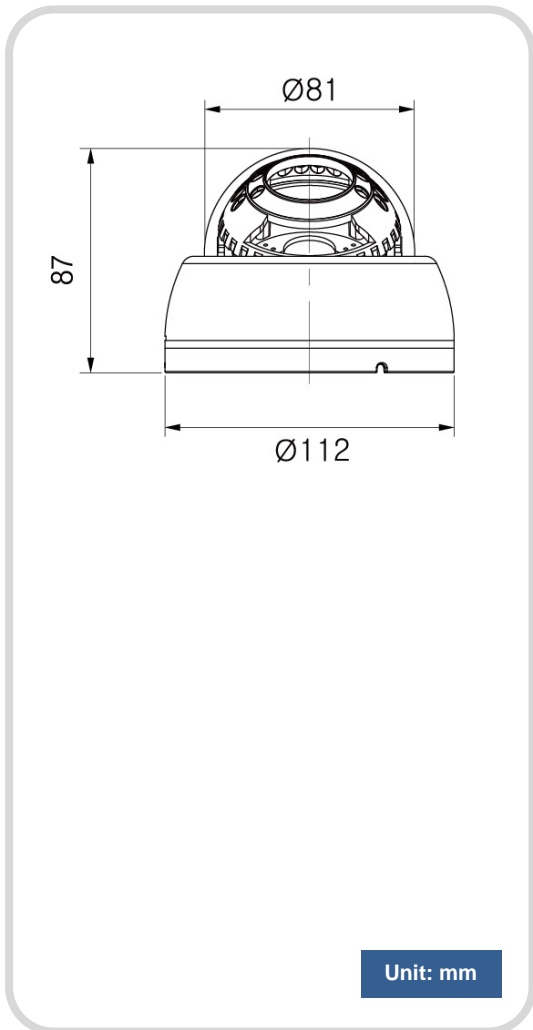

Specifications

| MODEL | DTS-2024PVMHD |
|-------------------------|---|
| Video | |
| Image Sensor | 1/2.8" 2.1Mega(1080p) PS-Sony CMOS |
| Scan mode | Progressive Scan |
| Total number of pixels | 1945(H) x 1109(V) |
| Number of active pixels | 1945(H) x 1097 (V) |
| Resolution | 1080P |
| Minimum illumination | Color:0.01Lux, 0.0003Lux with Sens-up(32x), LED On:0Lux |
| Video Output | AHD/TVI Selectable, extra CVBS |
| S/N Ratio | More than 50dB (AGC Off) |
| Lens | |
| Lens | 2.8 ~ 12mm MP Varifocal Lens H:101.7°(W)-32.2°(T), V:54.1°(W)-18.1°(T), D:120°(W)-37°(T) |
| Iris | DC Auto Iris |
| Function | |
| Day & Night | Auto / Color / BW / EXT |
| White Balance | ATW/MANUAL/AUTO ext/PRESET |
| AGC | Level (0~10) |
| DNR | Off / Low / Middle / High |
| Mirror / Flip | Off / On |
| Privacy Zone / Motion | 16 Zones / 4 Zones |
| Brightness | Level (0~20) |
| Shutter | Auto/Manual(1/30/25~1/30000)/FLICKER |
| Back light | HLC/WDR(120dB)/BLC |
| Defog | On/Off |
| IR LED | |
| LEDs | 24 LEDs (850nm) |
| Visible Distance | 15m |
| Environment | |
| Operating Humidity | 30 % ~ 90 % RH |
| Operating Temp. | - 10°C to 50°(14°Fto122°F) |
| Electrical | |
| Power Consumption | Max 5.4W |
| Power Supply | DC12V±10%, Dual Type: AC24/DC12V(Optional) |
| Mechanical | |
| Construction | Plastic body ,PC bubble |
| Dimension | 112(W)mm x 87(H)mm x ø81(Bubble) |
| Weight | About 0.35Kg |
| Certificate | |
| | CE, FCC, KC |